

5TT4 1 Remote Control Switches

SENTRON Protection, Switching, Measuring and Monitoring Devices



Remote control switches are used in infrastructure and buildings, as well as the switchgear engineering sector. They trip in the event of current inrushes, i. e. pulses, and then electromechanically save the switching position (i. e. without auxiliary power). Devices with direct voltage control voltage can be used in special applications such as battery-supplied systems.

■ Simple implementation of high feature control tasks

In conjunction with pushbuttons the remote control switches simplify the electrical installation because by using pushbuttons it is possible for example to switch the light from several locations. With special functions such as central, group and series control or shutter/blind control sequences, even high feature control tasks can be implemented easily and according to demand.

■ VDE mark and extremely quiet switching noise

All the 5TT4 1 remote control switches have the VDE mark. The switching noise is particularly low and adapted to requirements in residential buildings. The devices have a switching position indicator and are operated by hand. They can be equipped with an auxiliary switch.

Highlights

- Saving of the switching position even in the event of a power failure
- More safety during operation based on the VDE mark
- Devices with direct voltage control voltage can be used in special applications such as battery-supplied systems

Switching Devices

Remote control switches

Benefits













- All devices have a switching position indicator and are operated manually. This enables simple on-site operation and fast recognition of the switching state
- Remote control switches with central/group switching support convenient and high feature applications
- High functional reliability due to electromechanical design without fault-prone electronics
- All the remote control switches can be fitted with an additional auxiliary switch. This increases application flexibility

Technical specifications

	Remote control switches			Auxiliary switches		
	5TT4 101 5TT4 102 5TT4 105 5TT4 111 5TT4 112  5TT4 115	5TT4 103 5TT4 104	5TT4 12 5TT4 15	5TT4 13 5TT4 14	5TT4 900	5TT4 901
Standards	IEC 60669-1, IIEC 60669-2, IEC 60669-3, DIN EN 60669 (VDE 0632), DIN EN 60669-2-2, DIN EN 60669-2-2/A1					
Approvals	VDE 0632					
Contact type	1 NO 2 NO 1 NO 1 NC	3 NO 4 NO	1 NO 2 NO 3 NO 1 NO 1 NC	Series Shutter/blind	1 CO	
Manual operation	Yes					
Switching position indication	Yes					
Rated control voltage U_c	V AC V DC	8 ... 230 12 ... 110			-- --	
Operating range	$\times U_c$	0.8 ... 1.1			--	
Rated frequency f_c (AC types)	Hz	50			--	
Rated impulse withstand voltage U_{imp}	kV	4			1	
Rated power dissipation P_v						
• Magnet coil, only pulse	W/VA	4.5/7	9/13	4.5/7	--	
• Per contact at 16 A	W	1.2			--	
Minimum contact load	V AC; mA	10; 100			10; 100	AC/DC 5; 1
Rated operational current I_e at p.f.φ = 0.6 ... 1	A	16			5	0.1
Rated operational voltage U_e						
• 1 NO	V AC	250	--	250	--	250
• 2 NO	V AC	400	--	400	250	--
• 3 NO	V AC	--	400	400	--	--
• 4 NO	V AC	--	400	400	--	--
• 1 NO+ 1 NC	V AC	250	--	250	--	--
Glow lamp load at 230 V	mA	5			--	
• With 1x 5TT4 920 compensator	mA	25			--	
• With 2x 5TT4 920 compensators	mA	45			--	
Incandescent lamp load	W	2400			--	
Different phases permissible between magnet coil/contact		Permissible			--	
Contact gap	mm	> 1.2			< 1.2	
Safe isolation		Creepage distances and clearances between magnet coil/contact			mm > 6	
Pushbutton malfunction						
Protected against continuous voltage, safe due to design		Yes	PTC	Yes ¹⁾	Yes	--
Minimum pulse duration	ms	50			--	
Electrical service life at I_e/U_e or specified lamp load		500 00			In switching cycles	
Terminals ± screw (Pozidriv)		1			--	
Conductor cross-sections						
• Rigid	mm ²	1.5 ... 6			0.5 ... 4	
• Flexible, with end sleeve	mm ²	1 ... 6			0.75 ... 4	
Resistance to climate	Acc. to DIN 50015	At 95 % relative humidity			°C 35	
Permissible ambient temperature	°C	-10 ... +40			--	
Degree of protection	Acc. to EN 60529	IP20, with connected conductors			--	
Mounting position		Any			--	

¹⁾ For 2.5 MW 5TT4 123-0 devices with PTC

Selection and ordering data

	Contacts	U_e	I_e	U_c	U_c	Mounting width	DT	Order No.	PS*/P. unit	Weight per PU approx. kg
		V AC	A	V AC	V DC					
Remote control switches, auxiliary switches can be retrofitted										
	1 NO	250	16	230	115	1	▶	5TT4 101-0	1/12 units	0.135
				24			▶	5TT4 101-1	1 unit	0.138
				12			▶	5TT4 101-2	1 unit	0.134
				8			▶	5TT4 101-3	1 unit	0.133
	2 NO	400	16	230	115	2	▶	5TT4 102-0	1 unit	0.144
				24			▶	5TT4 102-1	1 unit	0.150
				12			▶	5TT4 102-2	1 unit	0.144
				8			▶	5TT4 102-3	1 unit	0.145
	3 NO	250	16	230	115	1	▶	5TT4 103-0	1 unit	0.199
				24			▶	5TT4 103-1	1 unit	0.198
				12			▶	5TT4 103-2	1 unit	0.211
				8			▶	5TT4 103-3	1 unit	0.210
	4 NO	250	16	230	115	1	▶	5TT4 104-0	1 unit	0.210
				24			▶	5TT4 104-1	1 unit	0.144
				12			▶	5TT4 104-2	1 unit	0.151
				8			▶	5TT4 104-3	1 unit	0.144
	1 NO+ 1 NC	250	16	230	115	1	▶	5TT4 105-0	1 unit	0.144
				24			▶	5TT4 105-1	1 unit	0.145
				12			▶	5TT4 105-2	1 unit	0.144
				8			▶	5TT4 105-3	1 unit	0.140
Remote control switches, DC applications										
	1 NO 	250	16	110	24	1	▶	5TT4 111-1	1 unit	0.126
				12			▶	5TT4 111-2	1 unit	0.126
				8			▶	5TT4 111-3	1 unit	0.126
	2 NO 	400	16	110	24	1	▶	5TT4 112-1	1 unit	0.130
				12			▶	5TT4 112-2	1 unit	0.130
				8			▶	5TT4 112-3	1 unit	0.130
	1 NO+ 1 NC	250	16	110	24	1	▶	5TT4 115-1	1 unit	0.144
				12			▶	5TT4 115-2	1 unit	0.147
				8			▶	5TT4 115-3	1 unit	0.144
Remote control switches with central ON/OFF switching, auxiliary switch cannot be retrofitted										
	1 NO	250	16	230	24	1.5	▶	5TT4 121-0	1 unit	0.155
				24			▶	5TT4 121-1	1 unit	0.165
	2 NO	400	16	230	24	1.5	▶	5TT4 122-0	1 unit	0.163
				24			▶	5TT4 122-1	1 unit	0.175
	3 NO	250	16	230	24	2.5	▶	5TT4 123-0	1 unit	0.227
				24			▶	5TT4 123-1	1 unit	0.163
1 NO + 1 NC	250	16	230	24	1.5	▶	5TT4 125-0	1 unit	0.163	
Remote control switches, with central and group ON/OFF switching, auxiliary switch cannot be retrofitted										
	1 NO	250	16	230	24	1.5	▶	5TT4 151-0	1 unit	0.145
				24			▶	5TT4 151-1	1 unit	0.144
	2 NO	400	16	230	24	1.5	▶	5TT4 152-0	1 unit	0.156
				24			▶	5TT4 152-1	1 unit	0.155

Switching Devices

Remote control switches

	Contacts	U_e V AC	I_e A	U_c V AC	U_c V DC	Mounting width MW	DT	Order No.	PS*/ P. unit	Weight per PU approx. kg	
	Series remote control switches Contact sequence 1 - 2 - 1+2 - 0 auxiliary switch cannot be retrofitted										
	2 NO	250	16	230		1	▶	5TT4 132-0	1 unit	0.143	
5TT4 132-0				12			▶	5TT4 132-3	1 unit	0.130	
	Shutter/blind remote control switches Contact sequence 1 - 0 - 2 - 0 Auxiliary switch cannot be retrofitted										
	2 NO	250	16	230		1	▶	5TT4 142-0	1 unit	0.144	
				24			B	5TT4 142-2	1 unit	0.145	
				12			C	5TT4 142-3	1 unit	0.143	
	Auxiliary switches One device can be retrofitted per remote control switch										
	1 CO 250 V AC/5 A	250	5			0.5	▶	5TT4 900	1 unit	0.049	
	1 CO For small outputs	AC/DC	0.1				▶	5TT4 901	1 unit	0.050	
5TT4 900											
	Compensators For increasing the glow lamp load by 20 mA										
		250	--			1	▶	5TT4 920	1 unit	0.073	
5TT4 920											

Dimensional drawings

5TT41 remote control switches

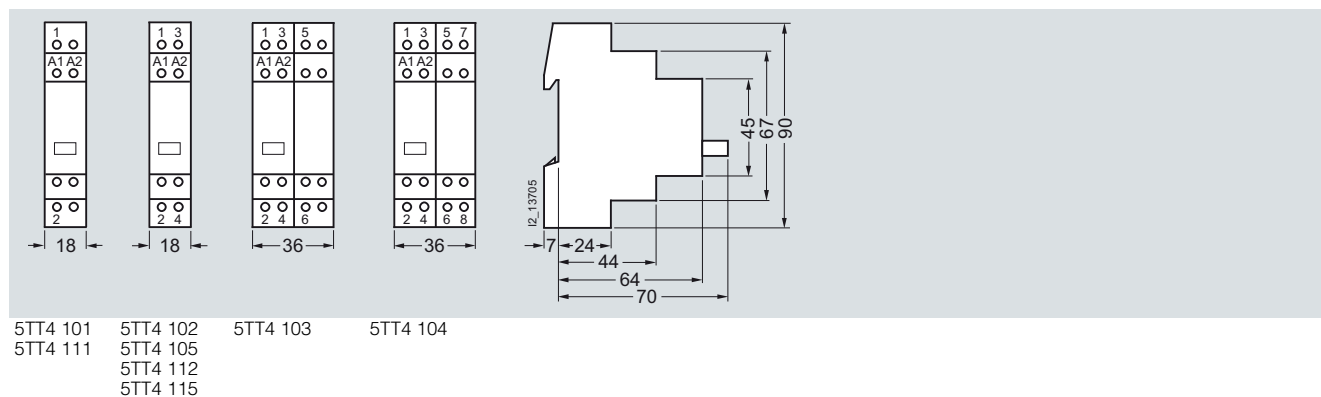

Remote control switches

5TT4 12 remote control switches with central ON/OFF switching

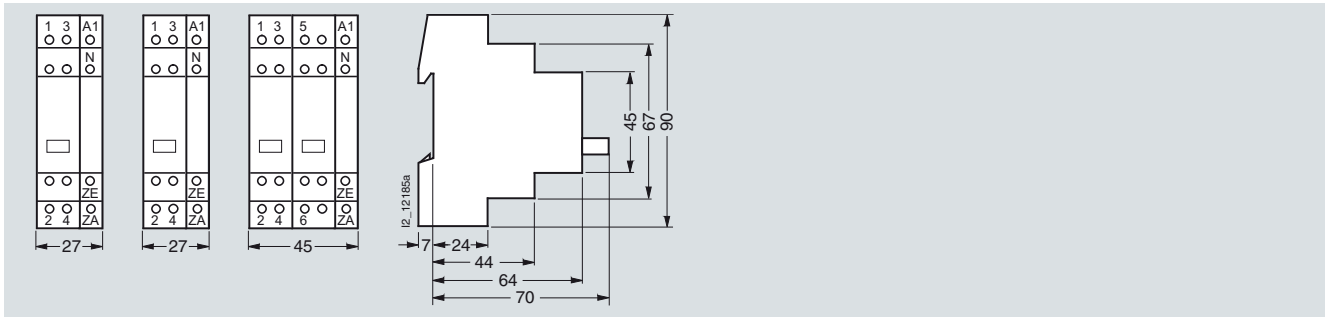

5TT4 121-0 5TT4 122-0 5TT4 123-0
 5TT4 121-2 5TT4 122-2
 5TT4 125-0

5TT4 132-0 series remote control switches and 5TT4 142 shutter/blind remote control switches

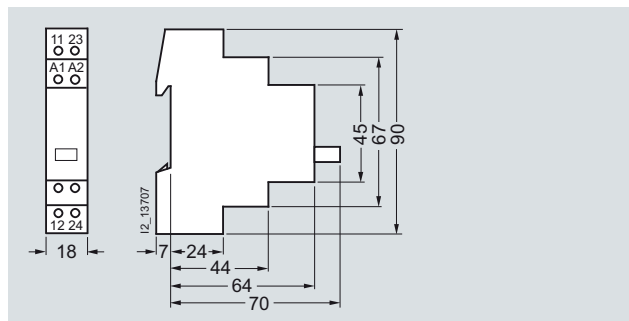

5TT4 132
 5TT4 142

Remote control switches with central and group ON/OFF switching

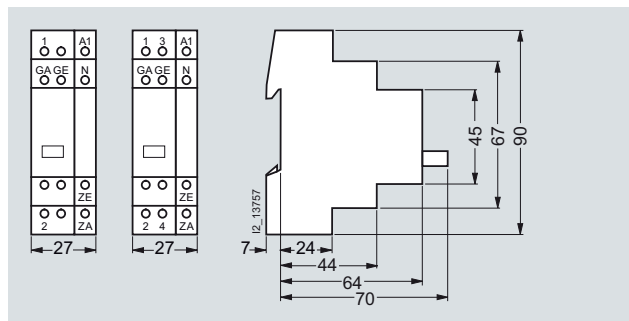

5TT4 151 5TT4 152

Auxiliary switches

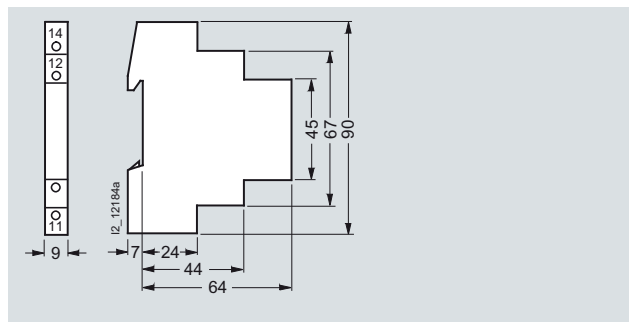

5TT4 90.

Compensators

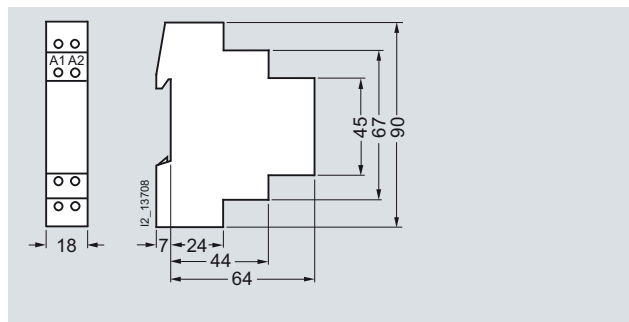

5TT4 920

Schematics



Switching Devices

Remote control switches

More information

Mechanical storage

Remote control switches are used to switch lighting by means of several pushbuttons. This makes complex cross/two-way switching unnecessary. With each pushbutton impulse, the remote control switch changes its contact position from OFF to ON, etc. In the event of a power failure, the last switching position is mechanically stored. Electromechanical remote control switches have no standby loss.

Pushbutton malfunction

Pushbuttons can jam, which may expose remote control switches to a continuous voltage. All remote control switches are protected against this type of malfunction through their design or through PTC.

Central switching functions

Versions with central ON/OFF function allow the central switching of all connected remote control switches, which can also be actuated over a time switch. All remote control switches can be switched to the ON or OFF switching state, regardless of their current switching state.

Contact sequences

1 - 2 - 1+2 - 0 or **1 - 0 - 2 - 0** means:

- 0: No contact closed
- 1: Only contact 1 closed
- 2: Only contact 2 closed
- 1+2: Contact 1 and contact 2 are closed.

The contact positions are constantly changing with each pushbutton impulse.

Note: The synchronous switching of the contacts cannot be guaranteed with parallel switching. Products with central/group switching must be used for the mutual control of several remote control switches.

Busbar mounting

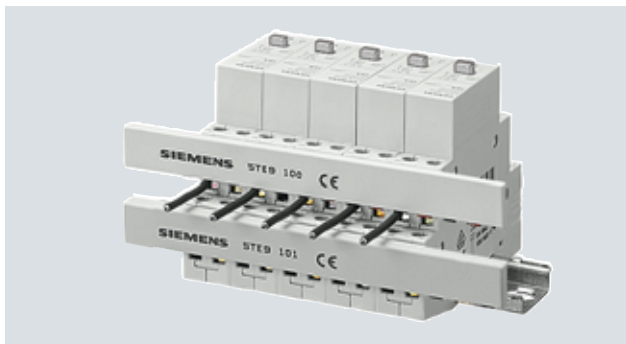

All 5TT4 1 remote control switches can be bus-mounted with each other. This saves time and space.

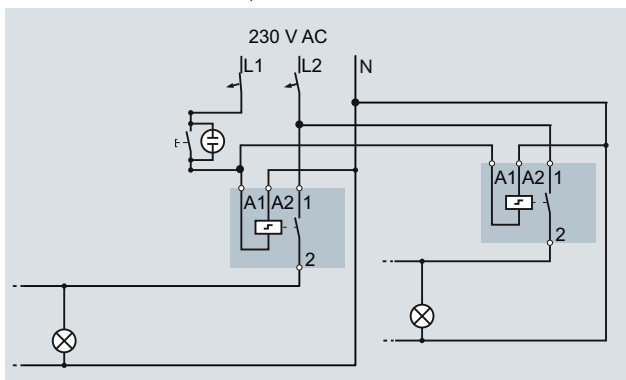

Switching example: 5TT4 101-0

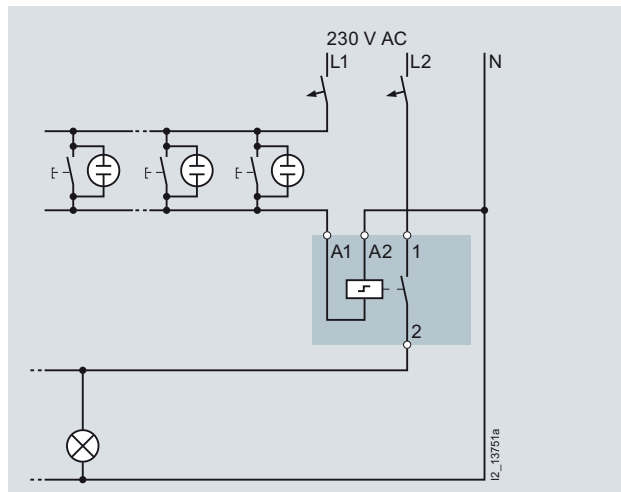

Single-phase lighting circuit with 230 V AC actuation, e.g. in office buildings

Switching example: 5TT4 122-0 with central ON/OFF switching

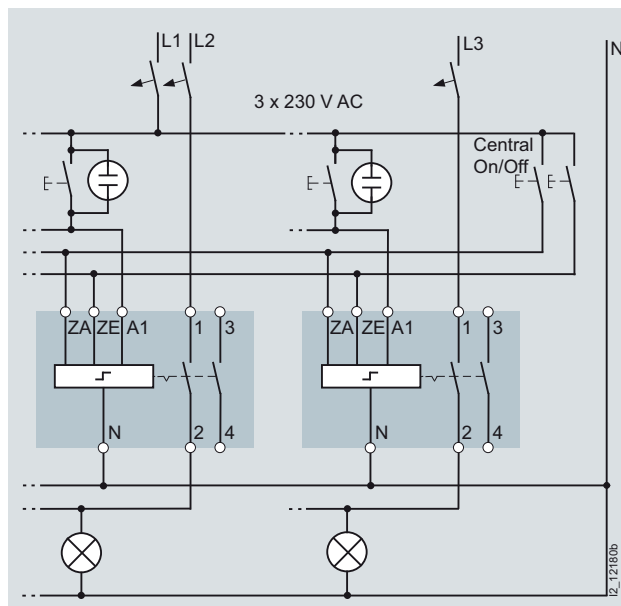

With the 2-pushbutton central "ON" and "OFF" function, all remote control switches can be switched on or off from a central point, e.g. at the start and end of work. A time switch with a one-second pulse (e.g. 7LF4 444-0) can also be used if desired. Once a central ON/OFF switching operation has been executed, the remote control switches can also be switched on and off locally at any time. Remote control switches with central ON/OFF switching can also be used for the quick and easy installation of a panic circuit/panic lighting using conventional installation methods.

The input terminals of the remote control switch must be connected to the same phase (L1, L2 or L3) and over the same residual current protective devices. Failure to do so may result in the accidental tripping of the residual current protective devices or short circuits.

Remote control switches

Switching example: 5TT4 101-4

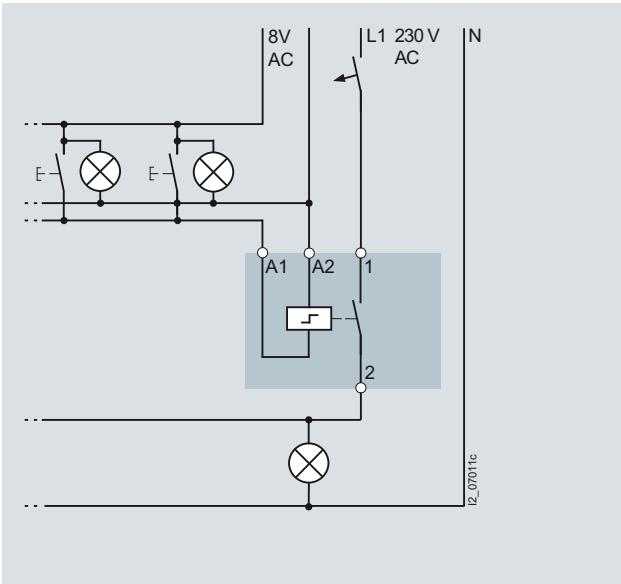

Single-phase lighting circuit with safety extra-low voltage 8 V AC, illuminated pushbutton.

This circuit is also suitable for the control of circuits with a high number of illuminated pushbuttons.

Switching example: 5TT4 121-0 with central ON/OFF switching and time switch

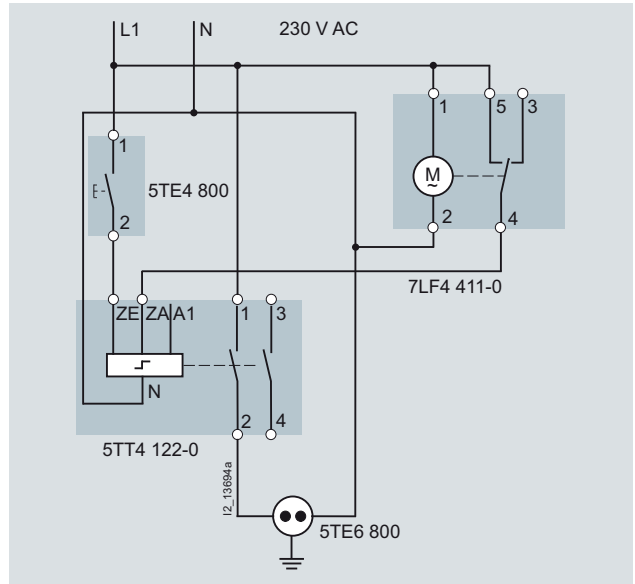

Printers and copiers are to be switched on with the pushbutton at the beginning of the working day. At the end of the working day, e.g. 6 p.m. to 10 p.m., an hourly one-second pulse of the time switch switches off the socket outlet. This ensures that printers and copiers are not "forgotten". If the device is switched on again after 6 p.m., a switch-off is actuated again hourly.

Switching example: 5TT4 152-0 with central ON/OFF switching and group ON/OFF switching

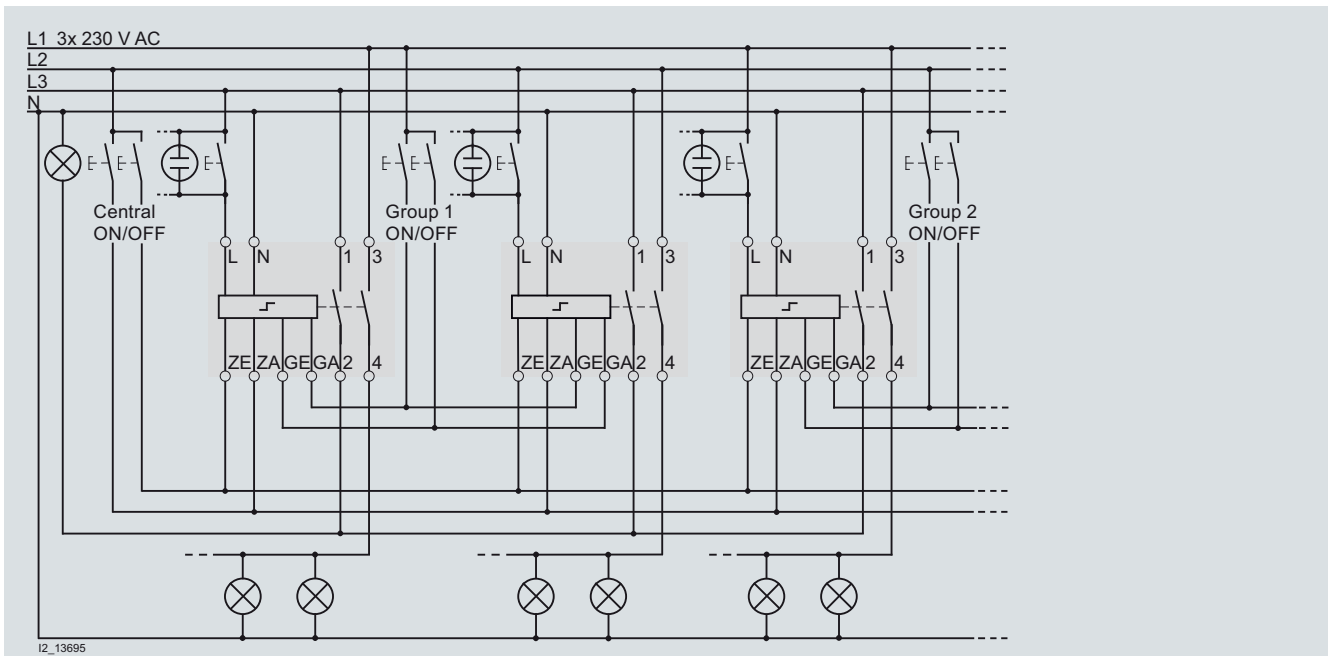

With the 2-pushbutton central "ON" and "OFF" function, all remote control switches can be switched on or off from a central point, e.g. at the start and end of work. With the 2-pushbutton group "ON" and "OFF" function, all remote control switches assigned to a group can be switched on or off, e.g. corridors. A digital 7LF4 4 time switch with a switching command of 1 s can also be used for the "Central" or "Group" function.

Once a central ON/OFF switching operation has been executed, the remote control switches can also be switched on and off locally at any time. The phase relations of ZA, ZE and GA, GE and L can be different. If contact 1/2 is used as check-back contact for the central "ON" and "OFF" function, as shown above, terminal 1 of all remote control switches must be in phase.

Switching example: Glow lamp load and 5TT4 920 compensator

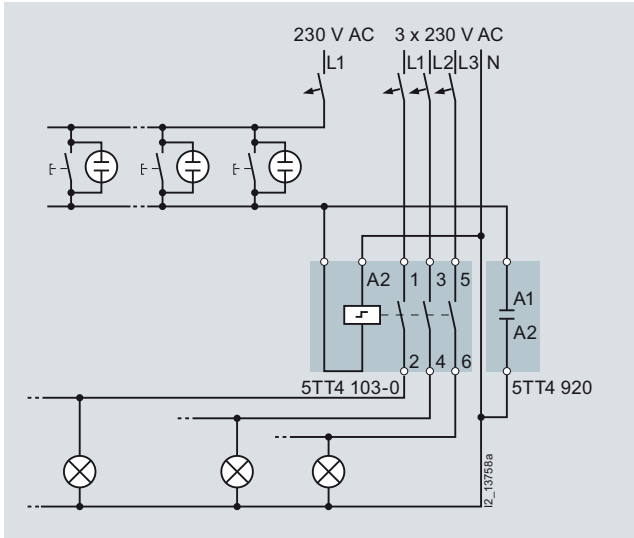

The use of multiple illuminated pushbuttons, in particular 230 V AC glow lamps, could cause the remote control switch to trip accidentally, or no longer drop out, due to the current used by the lamps. This may also occur in the case of high line capacities. Switching a 5TT4 920 compensator parallel to the coil increases the glow lamp load of the remote control switch from 5 mA to 25 mA.

The parallel switching of several compensators is also possible. The power consumption of 230V 5TG73.. glow lamps for push-buttons is: Low luminosity 0.18 mA – medium 0.9 mA – high 1.35 mA, the power consumption of 5SG7 35. LED lighting is approx. 1.5 mA.

To reduce capacitive coupling due to long cable lengths, we recommend using shielded cables. Particularly in systems with frequency converter controlled motors or with parallel cable routes (e.g. cable support systems), the induced current may impair the function of the devices.

Switching of lamps

			Remote control switches			
			5TT4 101 5TT4 102 5TT4 105 5TT4 111 5TT4 112 5TT4 115	5TT4 103 5TT4 104	5TT4 12 5TT4 15	5TT4 13 5TT4 14
Switching of transformers for halogen lamps	W		1200			
Fluorescent and compact lamps in ballast operation						
• Uncorrected	L18W L36W L58W	Unit(s)	35 35 25	30 30 20		
• Parallel-corrected	L18W/4.5 µF L36W/4.5 µF L58W/7 µF	Unit(s)	40 40 28	50 50 30		
• DUO switching, 2-lamp	L18W L36W L58W	Unit(s)	2 x 30 2 x 30 2 x 30	2 x 24 2 x 24 2 x 16		
Fluorescent and compact lamps with electronic ballast (ECG)						
• AC operation, 1-lamp	L18W L36W L58W	Unit(s)	36 36 24	30 30 20		
• AC operation, 2-lamp	L18W/4.5 µF L36W/4.5 µF L58W/7 µF	Unit(s)	2 x 22 2 x 22 2 x 15	2 x 18 2 x 18 2 x 12		

The information provided in this brochure contains descriptions or characteristics of performance which in case of actual use do not always apply as described or which may change as a result of further development of the products. An obligation to provide the respective characteristics shall only exist if expressly agreed in the terms of contract. Availability and technical specifications are subject to change without notice.

All product designations may be registered trademarks or product names of Siemens AG or supplier companies whose use by third parties for their own purposes may violate the rights of the owner.

© Siemens AG 2011 • PDF only: (E10003-E38-11T-G2023-7600) • PI 0911 En

Siemens AG
Industry Sector
Building Technologies Division
Postfach 10 09 53
93009 REGENSBURG
GERMANY