

Switching actuator (Relay) JB512C23

5WG1 512-4CB23

September 2015/ Page 1



Product and Applications Description

The JB512C23 Switching actuator (relay) is a KNX device with one switching output. The device is installed in a 4 x 4 inch junction box. The bus is connected via a bus terminal block. The actuator electronics are supplied via the bus voltage.

The JB512C23 can switch resistive loads (e.g. electrical heaters, incandescent lamps, high voltage halogen lamps), inductive loads (e.g. motor, low voltage halogen lamps with intermediate conventional transformers), or capacitive loads (e.g. low voltage halogen lamps with intermediate electronic transformers).

The actuator output may be configured independently to provide switching, manual override, forced control, logical gate and status reporting. Furthermore, if required, time-limited switching instead of permanent switching on can be enabled via an optional "Night mode" object (e.g. for lighting while cleaning), if need be with a warning before switching off by multiple switching the output on and off (flashing).

Amongst others, the application program includes an optional count of switching cycles and operating hours with threshold monitoring for each output and an integrated 8-bit scene control, in which the output can be incorporated into up to 8 scenes.

Each output of the actuator may be set to one of the following operating modes:

- Normal operation
- Timer operation

Building site function

The building site function provided ex-factory enables switching the building site lighting on and off via bus wall switches and actuators, even if these devices have not yet been commissioned with ETS.

Application Program

The JB512C23 Switching actuator (relay) needs the application program "07 B0 A1 Switch actuator 982D02".

Example of Operation

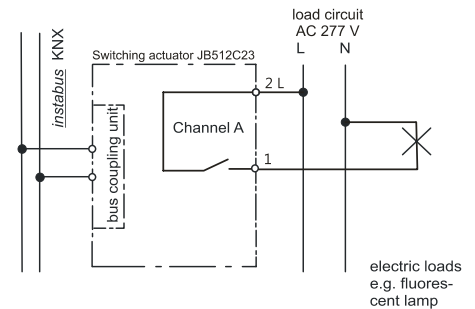

Technical Specifications

Power supply

- via the bus line
- KNX bus voltage: DC 24V (DC 21 ... 30 V) via KNX/EIB bus line
- KNX bus current: < 10 mA

Outputs

- 1 output (potential-free, bistable relay contact)
- switching characteristic: set in parameter list according to application program
- rated voltage: 120 - 277 Vac / 347Vac, 50 / 60 Hz
- max. relay position changes per minute: 60

Maximum load

- 15 A @ 347 Vac (General Purpose)
- 15 A @ 347 Vac Ballast (200µF max.)
- 20 A @ 277 Vac (General Purpose)
- 20 A @ 277 Vac Ballast (200µF max.)
- 20 A @ 120 Vac (General Purpose)
- 20 A @ 120 Vac Ballast (200µF max.)
- 1,5 HP @ 120 Vac
- 3 HP @ 277 Vac

Control elements

- 1 learning button: For switching between normal operating mode and addressing mode

Display elements

- 1 red LED: For monitoring bus voltage and for displaying normal mode / addressing mode

Connections

- Bus line : Bus connection pins for connection of the screwless bus terminal block (red-black) 0.6...0.8 mm Ø single core, strip insulation 5mm
- Load circuit: see Location and Function of Interface Elements

Physical specifications

- housing: plastic
- dimensions (L x W x D): length : 70 mm (2.76 inch) width: 90 mm (3.54 inch) depth: 44.6 mm (1.76 inch)
- weight: approx. 170 g
- fire load: approx. 5 MJ
- Installation: in a junction box (min. dimensions (L-W-D)) Length: 4 inch (101.6 mm) Width: 4 inch (101.6 mm) Depth: 2 inch (50.8 mm)

Electrical safety

- Degree of pollution (according to IEC 60664-1): 2
- Type of protection (according to EN 60529): IP 20
- Overvoltage category (according to IEC 60664-1): III
- Bus: safety extra low voltage SELV DC 24 V
- Relay with µ - contact
- Device complies with: EN 50428

Electromagnetic compatibility

complies with EN 50428

Environmental specifications

- Ambient operating temperature: -5 ... +45 °C (+23 ... +113 °F)
- Storage temperature: -25 ... +70 °C (-13 ... +158 °F)
- Relative humidity (not condensing): 5 % ... 93 %

Reliability

- Failure rate: 249 fit at 40°C

Markings

KNX, EIB, UL

Listings and Certifications

CE mark

complies with the EMC regulations (residential and functional buildings) and low voltage regulations

cUL listed (E464611)

UL 916, Open Energy Management Equipment

Location and Function of the Interface Elements

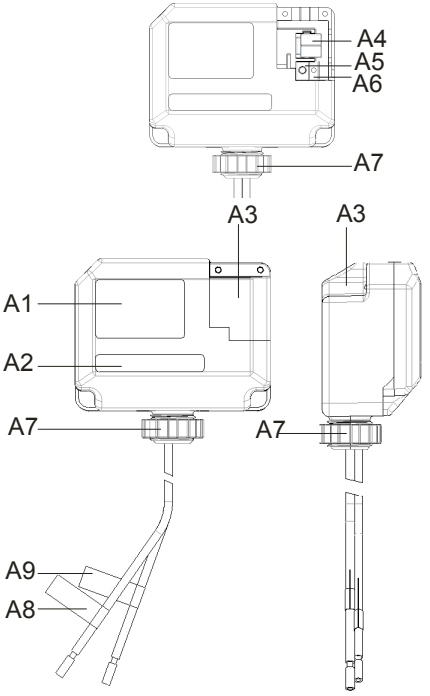

- A1 Type label (with space for physical address of the actuator)
- A2 Identification number of the device
- A3 Protective lid over bus connection
- A4 Bus connection terminal block for single core conductors with 0.6...0.8 mm Ø
- A5 LED for indicating normal operating mode (LED off) or addressing mode (LED on); returns to normal operating mode automatically after receiving the physical address
- A6 Learning button for switching between normal operating mode and addressing mode and for receiving the physical address
- A7 1/2 inch screw nut
- A8 Wire (red) Load A (AWG #12)
- A9 Wire (black) Line (Hot) (AWG #12)

Dimension Diagram

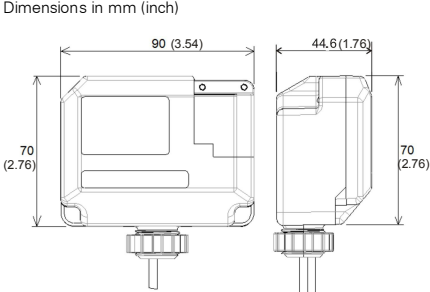

WARNING

Hazardous voltage.
Can cause death, or serious injury or property damage.

The device must not be opened.
A faulty device should be returned to the local Siemens sales office or distributor.

The device must be mounted and commissioned by a factory trained person.
The prevailing safety rules must be observed!
Mount in dry locations only!

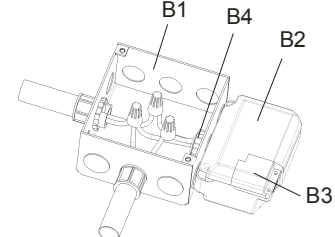
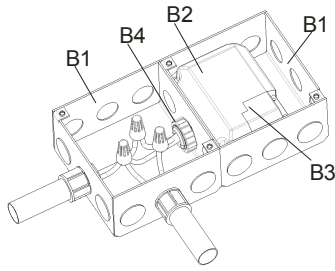

- B1 4" x 4" Junction Box
- B2 Device
- B3 Bus connection pins of the module for connection of the bus terminal block for single core conductors with 0.6...0.8 mm Ø
- B4 1/2 inch screw nut

Mounting and Dismounting

- Mounting of a JB module:
 - Option 1 (mounting inside a J-Box)
 - Insert the thread of the JB module (B2) into the 1/2 inch knockout between two adjacent J-Boxes (B1)
 - Fasten the JB module (B2) with the 1/2 inch thread nut (B4)
 - Remove the protective lid (B3) and connect the bus wire to the bus terminal block (A4)
 - Connect the wires from the device to the field wires using wire nuts (not provided in package)
 - Option 2 (mounting outside of a J-Box)
 - Insert the thread of the JB module (B2) into the 1/2 inch knockout of the J-Box (B1)
 - Fasten the JB module (B2) with the 1/2 inch thread nut (B4) to the J-Box (B1)
 - Connect the bus wire to the bus terminal block under the protective cover (B3)
 - Connect the wires from the device to the field wires using wire nuts (not provided in package)
- Assignment of the Physical Address:
 - A short push (< 2 s) of learning button (A6) enables the addressing mode, which is indicated when the LED is continuously on (A5). The device returns to normal operating mode (LED Off) automatically after receiving the physical address or if the learning button is pushed again.
 - A very long push (> 20 s) of the learning button resets the device to factory settings. This is indicated by constant flashing for 8 seconds.
 - A long push (> 5 s up to 20 s) of the learning button enables the Connection Test for commissioning with Desigo. This mode can be disabled by a short push any time.
 - Install the protective lid (B3) and fasten with screws (provided in package)
- Dismounting a JB module:
 - Disconnect power to the module
 - Remove the wire nuts and bus connection
 - Unfasten the 1/2 inch thread nut (B4) connecting the JB module (B2) to the J-Box (B1)
 - Remove the JB module (B2) from the J-Box (B1)

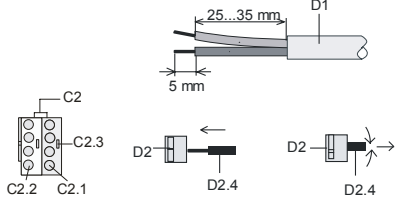

Wiring

- Bus connection**
- Slipping off/on bus connection blocks
- The bus connection block consists of two components (C2.1 and C2.2) with four terminal contacts each. Take care not to damage the two test sockets (C2.3) by accidentally connecting them to the bus cable or with the screw driver (e.g. when attempting to unplug the bus connection block).
- Carefully put the screw driver to the wire insertion slit of the bus connection block's grey component (C2.2) and
 - pull the bus connection block (C2) from the module.
- Slipping off bus connection blocks
- Carefully put the screw driver to the wire insertion slit of the bus connection block's grey component (C2.2) and
 - pull the bus connection block (C2) from the module.

Note

Don't try to remove the bus connection block from the bottom side. There is a risk of shorting-out the device!

- Slipping on bus connection blocks
- Slip the bus connection block (C2) onto the guide slot of the module and
 - press the bus connection block (C2) down to the stop.

Connecting and Disconnecting bus cables

- Connecting bus cables
- The bus connection block (D2) can be used with single core conductors Ø 0.6...0.8 mm.
 - Remove approx. 5 mm of insulation from the conductor (D1) and plug it into the bus connection block (D2) (red = +, grey = -)
- Disconnecting bus cables
- Unplug the bus connection block (D2) and remove the bus cable conductor (D1) while simultaneously wiggling it.

Connecting mains and load circuit:

- Connect wires
- Connect wire leads using wire nuts.